

VALVE BODY CAVITY SAE 3 WAYS
 VENTILGEHAUSE FORMBOHRUNG SAE 3 WEGE

Valve body cavity SAE 3 ways – Connections type gas

Material: aluminium (2011-FC1) anodized.

Max operating pressure: 210 bar

Ventilgehäuse Formbohrung SAE 3 Wege – Anschlüsse Typ Gas

Werkstoff: aluminium 2011 (AlCuBiPb) eloxiert.

Max Betriebsdruck: 210 bar

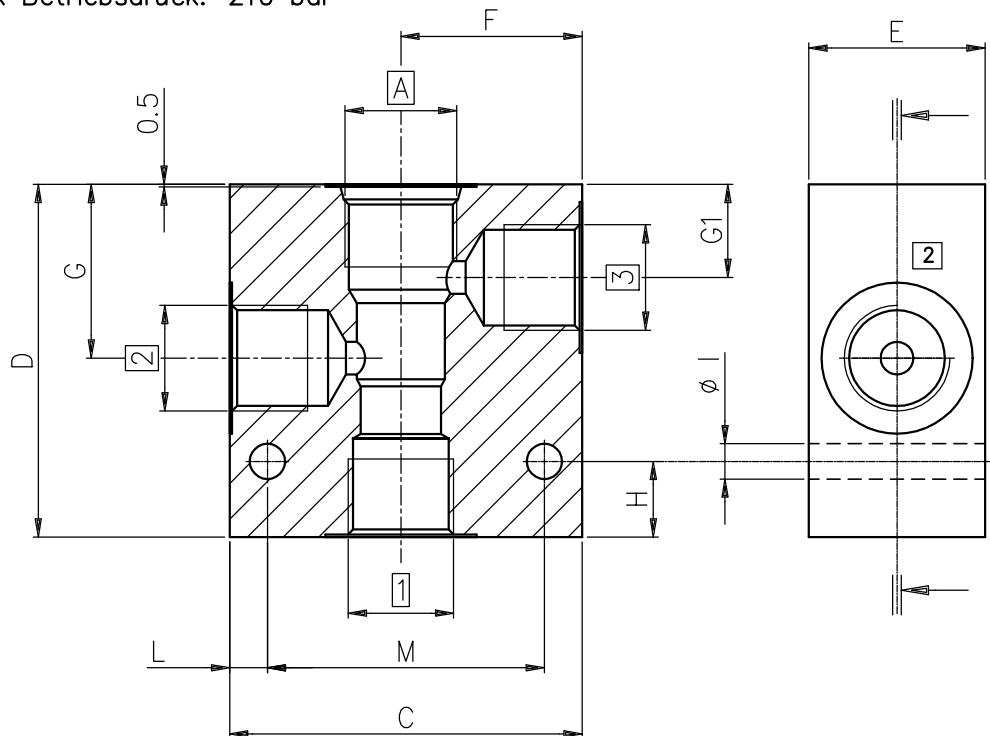

CAVITY FORMBOHR.	A	1-2	3	C	D	E	F	G	G1	H	I	L	M	Weight Gewicht (Kg)
SAE 8/3	3/4"-16	3/8"G	3/8"G	59	65	30	30	29.5	15	15	7	7.5	44	0.3
SAE 10/3C	7/8"-14	1/2"G	1/4"G	69	75	40	32	31.5	14.5	15	7	7.5	54	0.5
SAE 10/3	7/8"-14	1/2"G	1/2"G	69	75	40	35.5	34.5	18.5	15	7	7.5	54	0.5
SAE 12/3	1"1/16-12	3/4"G	3/4"G	79	100	40	40	53.5	28.5	18	9	10	59	0.9
SAE 16/3	1"5/16-12	1"G	1"G	98	110	50	49.5	54	25.5	28	9	12	74	1.5

CAVITY FORMBOHR.	Article-code: Typ:
SAE 8/3	EAD083038
SAE 10/3C	EAD103112
SAE 10/3	EAD103012
SAE 12/3	EAD123034
SAE 16/3	EAD163010

Set of 10 pcs.
Satz von 10 Stk.